



WILLIAM PATERSON UNIVERSITY

OFFICE OF CAPITAL PLANNING, DESIGN, AND CONSTRUCTION
300 POMPTON ROAD • WAYNE, NEW JERSEY 07470-2103
973.720.2548 FAX 973.720.2829 • WWW.WPUNJ.EDU

ADDENDUM NO. 2

TO: All Prospective Bidders
DATE: April 8, 2016
PROJECT: **Music Department Interior Improvements
(WP-16-02-01)**

This Addendum No. 2 forms a part of the contract bidding documents and answers all questions submitted regarding the bidding documents.

Clarifications and Update:

1. Item #3 in Scope of Services states: "In Practice Rooms where there is an existing duplex outlet in a wall that will be covered by a new sound barrier wall, move the electrical outlet to the face of the new sound barrier wall". This clarification changes the answer given to Addendum No. 1, Question 6.

There will be no changes to the existing electrical outlets in the Music Practice Rooms. Instead, Bidders should include the cost for furnishing and installing fifteen (15) 12" x 12" access panels in the new sound isolation walls. These access panels will provide access to the duplex outlets behind the new walls. Provide General Purpose Access Doors BA-AHD (attached), or equal.

END OF ADDENDUM NO. 2

GENERAL PURPOSE ACCESS DOOR FOR ALL SURFACE TYPES

BA-AHD

INSTALLATION



PIANO HINGE
ON DOORS OVER 24"
(HEIGHT OR WIDTH)

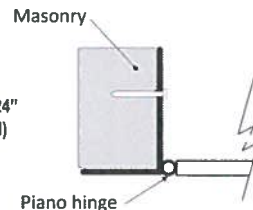

DIMENSIONS AND APPEARANCE

LEED ready: This product contributes to LEED® credits.

Made in 5 days

DOOR SIZE W x H inches (MM)	NUMBER OF LOCKS	WEIGHT LBS	KG
6 x 6 (152 x 152)	1	2	0.9
8 x 8 (203 x 203)	1	3	1.4
8 x 12 (203 x 304)	1	4	1.8
10 x 10 (254 x 254)	1	4	1.8
12 x 12 (304 x 304)	1	5	2.3
12 x 16 (304 x 406)	1	6.2	2.8
12 x 18 (304 x 457)	1	7	3.2
12 x 24 (304 x 609)	1	8	3.6
14 x 14 (356 x 356)	1	7	3.2
16 x 16 (406 x 406)	1	8	3.6
18 x 18 (457 x 457)	1	9	4.1
18 x 24 (457 x 609)	1	13	5.9
20 x 20 (508 x 508)	1	11	5.
22 x 22 (558 x 558)	1	13	5.9
* 22 x 30 (558 x 762)	2	17	7.7
* 22 x 36 (558 x 914)	2	19	8.6
* 24 x 24 (609 x 609)	1	15	6.8
* 24 x 30 (609 x 762)	2	20	9.1
* 24 x 36 (609 x 914)	2	22	10
* 24 x 48 (609 x 1219)	2	28	12.7
* 30 x 30 (762 x 762)	4	23	12.7
* 36 x 36 (914 x 914)	4	31	14.1

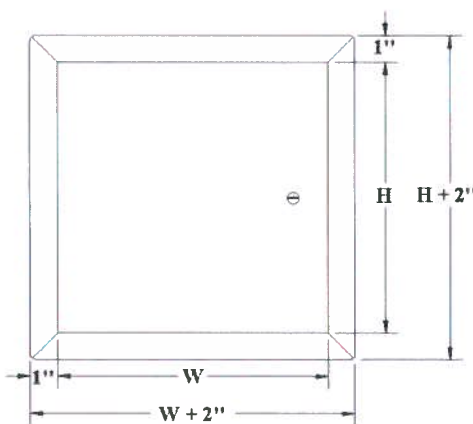

Rough wall opening is door size + 1/4" or + 6mm

*Piano hinge on doors over 24 inches (height or width) - The LHD model is recommended for over 1296 sq. inches

DESCRIPTION AND MATERIAL SPECIFICATION

Material: 16 gauge cold rolled steel
Hinge: hidden pin hinge
 continuous piano type on doors
 over 24" (height or width)
Lock / latch: screwdriver operated cam latch
Finish: high quality white powder coat primer
Packaging: individually wrapped, 1 per box

POPULAR OPTIONS
Lock / latch: For complete list of options
 go to: www.BestAccessDoors.com
 key operated cylinder cam latch,
 hex head cam latch, pinned hex
 head cam latch, handle operated cam latch,
 mortise preparation for cylinder.

Material: stainless steel 304 #4 (brushed finish)
Gasketing: neoprene gasket



PROJECT DATA

PROJECT NAME:	QTY	W	H	OPTIONS
ARCHITECT:				
DEALER:				
CONTRACTOR:				
LOCATION:	SPECIAL INSTRUCTIONS:			
DATE:				
TAGGING INSTRUCTIONS:	SUBMITTAL APPROVAL: (signature or stamp)			

ADDRESS: P.O Box 4668, #76520 New York, NY 10163-4668
WAREHOUSES: California, Colorado, Florida, Illinois, Pennsylvania, Texas

Tel.: 1-800-483-0823
Fax: 1-888-828-6021

www.bestaccessdoors.com
sales@bestaccessdoors.com